

PARTS LIST						
NO.	DESCRIPTION	PART NO.	DWG NO.	MATL	QTY	⊗ ⊕
1	HEAD SUB-ASSY.		B-18372	316 SS	1	⊗ ⊕
2	HEAD		C-18366	ASME SA479-A86 316 SS	*	
3	HEAD ADAPTER		A-12739	316 SS	*	
4	TIE ROD		A-12737	316 SS	1	⊗ ⊕
5	FILTER TUBE		-----	-----	--	⊗ ⊕
6	SUPPORT CORE		C-10118	ST.STL.	--	⊕
7	ELEMENT RETAINER		A-12740	316 SS	1	⊗ ⊕
8	BOWL		C-18364	ASME SA479-A86 316 SS	1	
9	O-RING (-225)		-----	TEFLON	--	⊕
10	O-RING (-223)		-----	VITON	1	⊗ ⊕
11	PIPE PLUG		A-11319	316 SS	1	⊗ ⊕
12	THREAD PROTECTOR		A-11862	PLASTIC	1	
13	THREAD PROTECTOR		A-11862	PLASTIC	2	
--	MOUNTING BRACKET KIT		A-10235	STL/PLD	--	⊕

### LEGEND

⊗ = REPLACEABLE PARTS

⊕ = OPTIONAL PARTS

[ ] = INDICATE FILTER GRADE (BX OR DX)

\* = INCLUDED IN HEAD SUB-ASSEMBLY (ITEM 1)

-SEE NOTE 2.  
-SEE NOTE 2.

-SEE NOTE 4.

REVISIONS				
REV	ECN.NO.	DESCRIPTION	NAME	DATE
-	----	ORIGINATED FOR PRODUCTION	PES	03/02
A	1267	CHANGED PER ECN	EHS	09/03

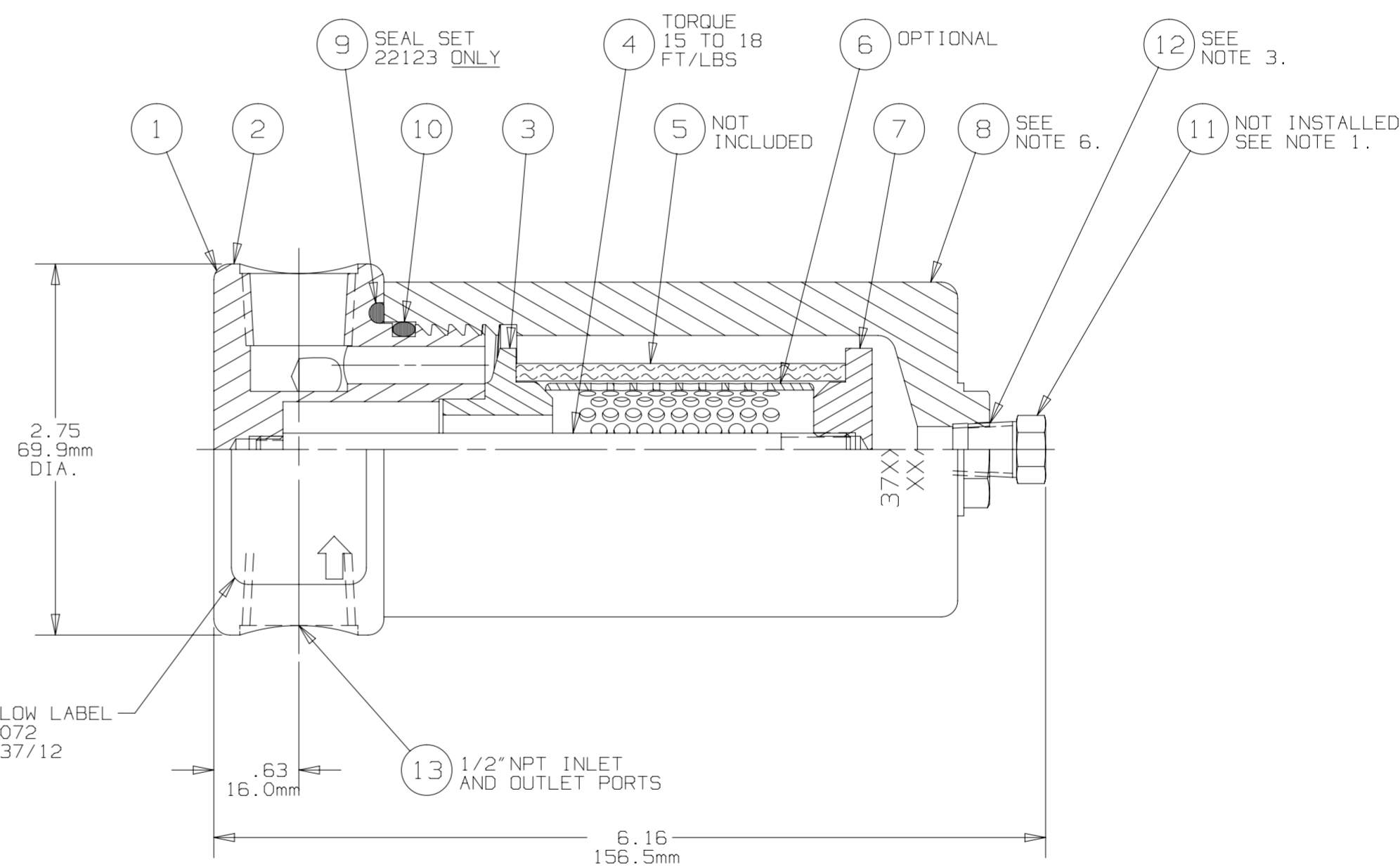
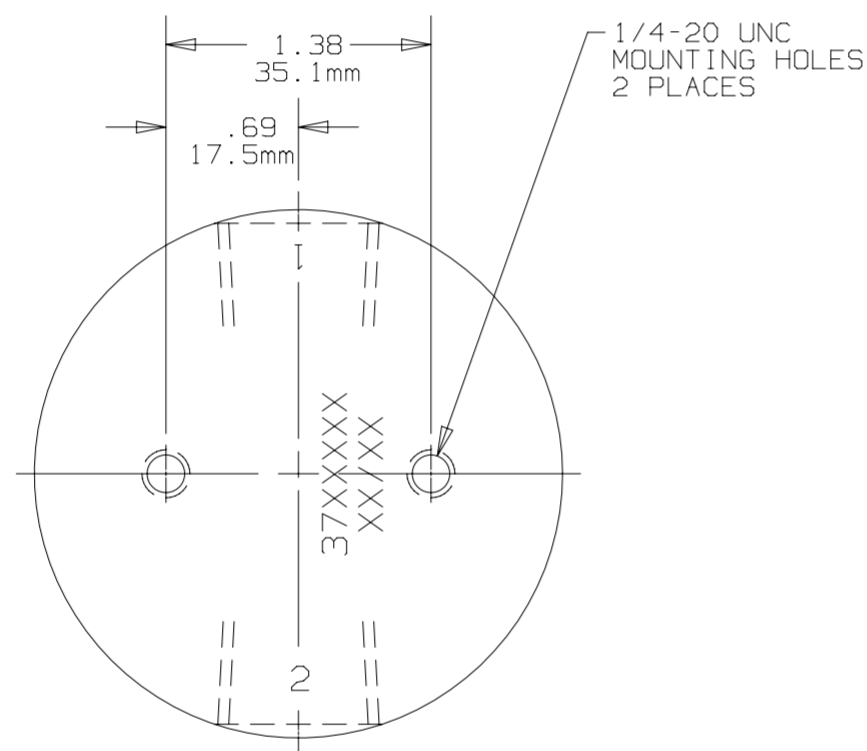

### NOTES:

- ALL ASSEMBLY AND PACKAGING MUST BE PERFORMED IN ACCORDANCE WITH THE APPROPRIATE MANUFACTURING METHOD SHEET SPECIFIED FOR THIS ASSEMBLY.
- O-RINGS TO BE LUBRICATED WITH APPROVED LUBRICANT ONLY.
- HOUSING TO BE SHIPPED WITH PLASTIC THREAD PROTECTORS (ITEMS 12 & 13) INSTALLED.
- MOUNTING BRACKET KIT INCLUDES BRACKET AND (2) MOUNTING SCREWS.
- PRESSURE RATING: 4000 PSIG (276 barg) AT 200°F (93°C).
- PTFE THREAD LUBRICANT MUST BE APPLIED TO HEAD SUBASSEMBLY (ITEM 1) PRIOR TO ASSEMBLY OF BOWL (ITEM 8)

SEE NOTE 1. [ ]

EU37/12	AS PACKAGED
EU37/12-1	AS ASSEMBLED
PART NO.	DESCRIPTION

REPLACEMENT SEAL SETS				
SEAL SET NUMBER	MAT'L	CONSISTS OF		
		NO	QTY	PART NO.
22130	VITON	10	1	22130-2
22132	TEFLON	9	1	22132-3
	TEF/VIT	10	1	22132-2
22131	SILICONE	10	1	22131-2

THIRD ANGLE PROJECTION

TOLERANCES EXCEPT AS NOTED

.XX	± .015
X.Xmm	± .38mm
.XXX	± .005
XX.XXmm	± .13mm

ANGULAR ±1°

63/ SURFACE ROUGHNESS OR BETTER

REMOVE ALL BURRS AND SHARP EDGES.

THIS DOCUMENT CONTAINS INFORMATION THAT IS CONFIDENTIAL AND PROPRIETARY TO PARKER FILTRATION AND SEPARATION DIVISION ("PARKER"). THIS DOCUMENT IS FURNISHED ON THE UNDERSTANDING THAT THE DOCUMENT AND THE INFORMATION IT CONTAINS WILL NOT BE COPIED OR DISCLOSED TO OTHERS OR USED FOR ANY PURPOSE OTHER THAN CONDUCTING BUSINESS WITH PARKER, AND WILL BE RETURNED AND ALL FURTHER USE DISCONTINUED UPON REQUEST BY PARKER. COPYRIGHT PARKER, YEAR OF COPYRIGHT IS FIRST YEAR INDICATED ON THIS DOCUMENT. ALL RIGHTS RESERVED.

ENG. APVD.:	DATE:
CH'KD BY:	DATE:
DRAWN BY:	DATE:
PES	03/28/02
MAT'L:	SEE PARTS LIST

**Parker Filtration**

Parker Hannifin Corporation  
Filtration and Separation Division  
Tewksbury, Massachusetts USA

**BALSTON**

TITLE: FILTER HOUSING

FINISH: -----

MODEL NO.: EU37/12

SCALE: 1 : 1

SHEET: 1 OF 1

P/N: SEE TABLE

DWG. NO.: C-18368